

**This electronic collection of documents is provided  
for the convenience of the user  
and is Not a Certified Document –**

**The documents contained herein were originally issued  
and sealed by the individuals whose names and license  
numbers appear on each page, on the dates appearing  
with their signature on that page.**

**This file or an individual page  
shall not be considered a certified document.**

COMPUTED BY: \_\_\_\_\_ AMF \_\_\_\_\_ DATE: 03/16/2017  
 CHECKED BY: \_\_\_\_\_ DATE: \_\_\_\_\_

PROJECT REFERENCE NO.	SHEET NO.
B-6035	X-1A

DIVISION OF HIGHWAYS  
 STATE OF NORTH CAROLINA

**CROSS SECTION INDEX OF SHEETS**

**INDEX OF SHEETS**

DESCRIPTION	SHEET NO.
CROSS SECTION INDEX OF SHEETS AND CROSS SECTION EARTHWORK SUMMARY	X-1A
-L-	X-1 TO X-4

**CROSS SECTION EARTHWORK SUMMARY**  
 IN CUBIC YARDS

STATION -L-	UNCLASSIFIED EXCAVATION	EMBT
10 + 50.00	0	0
10 + 75.00	10	1
11 + 00.00	20	3
11 + 25.00	26	42
11 + 44.01 (BEGIN BRIDGE)	15	55
12 + 16.61 (END BRIDGE)	0	0
12 + 25.00	0	3
12 + 50.00	5	6
12 + 75.00	11	5
12 + 90.00	4	1

NOTE: EMBANKMENT COLUMN DOES NOT INCLUDE BACKFILL FOR UNDERCUT.

8/23/99

0 2.5 5	PROJ. REFERENCE NO.	SHEET NO.
	B-6035	X-1

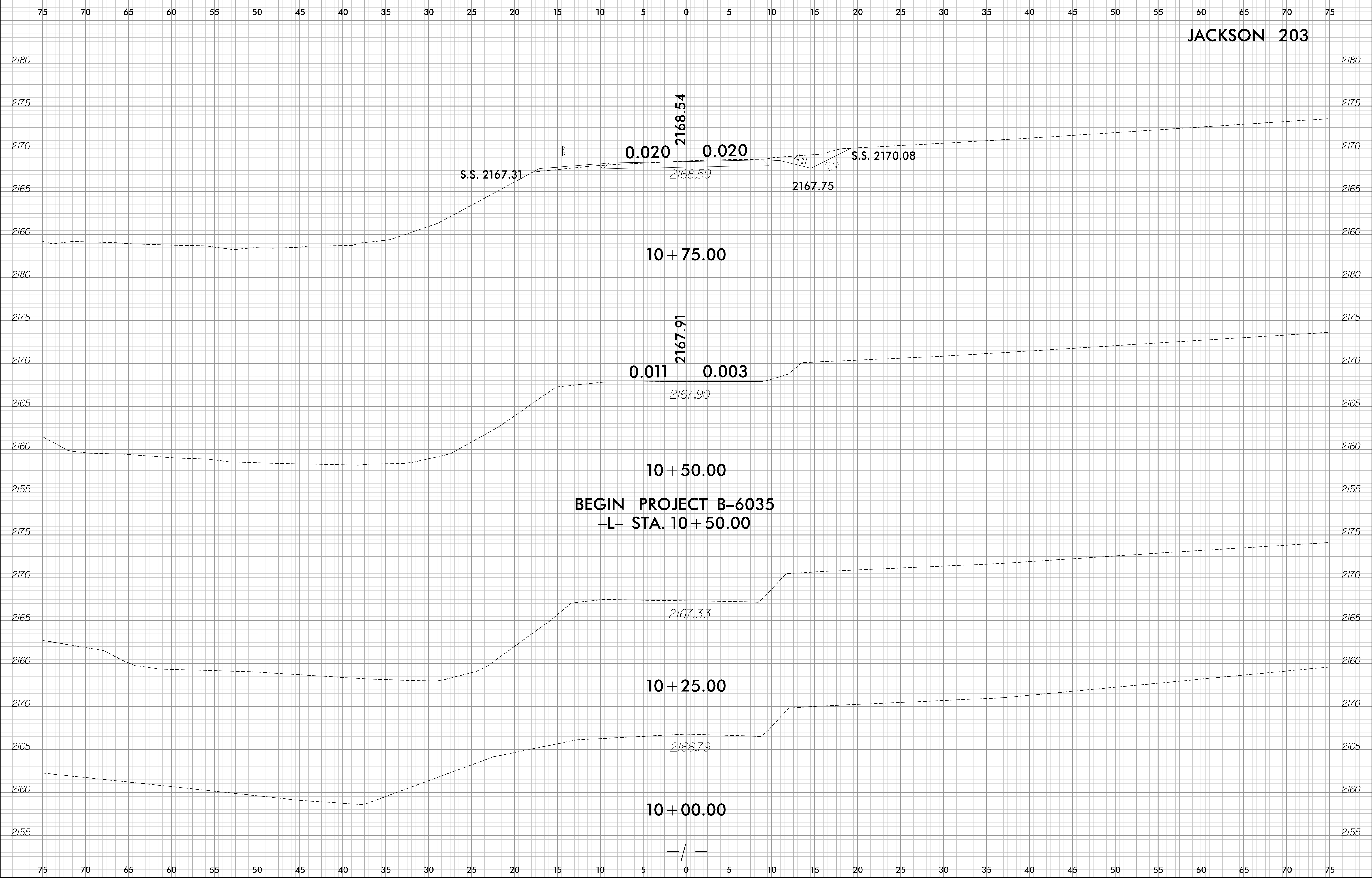

8/26/2019 7:05:59 AM  
\\scc\Jackson203\_rdy\_xpl\_L.dgn  
User:ldayes

8/23/99

0 2.5 5	PROJ. REFERENCE NO.	SHEET NO.
	B-6035	X-2

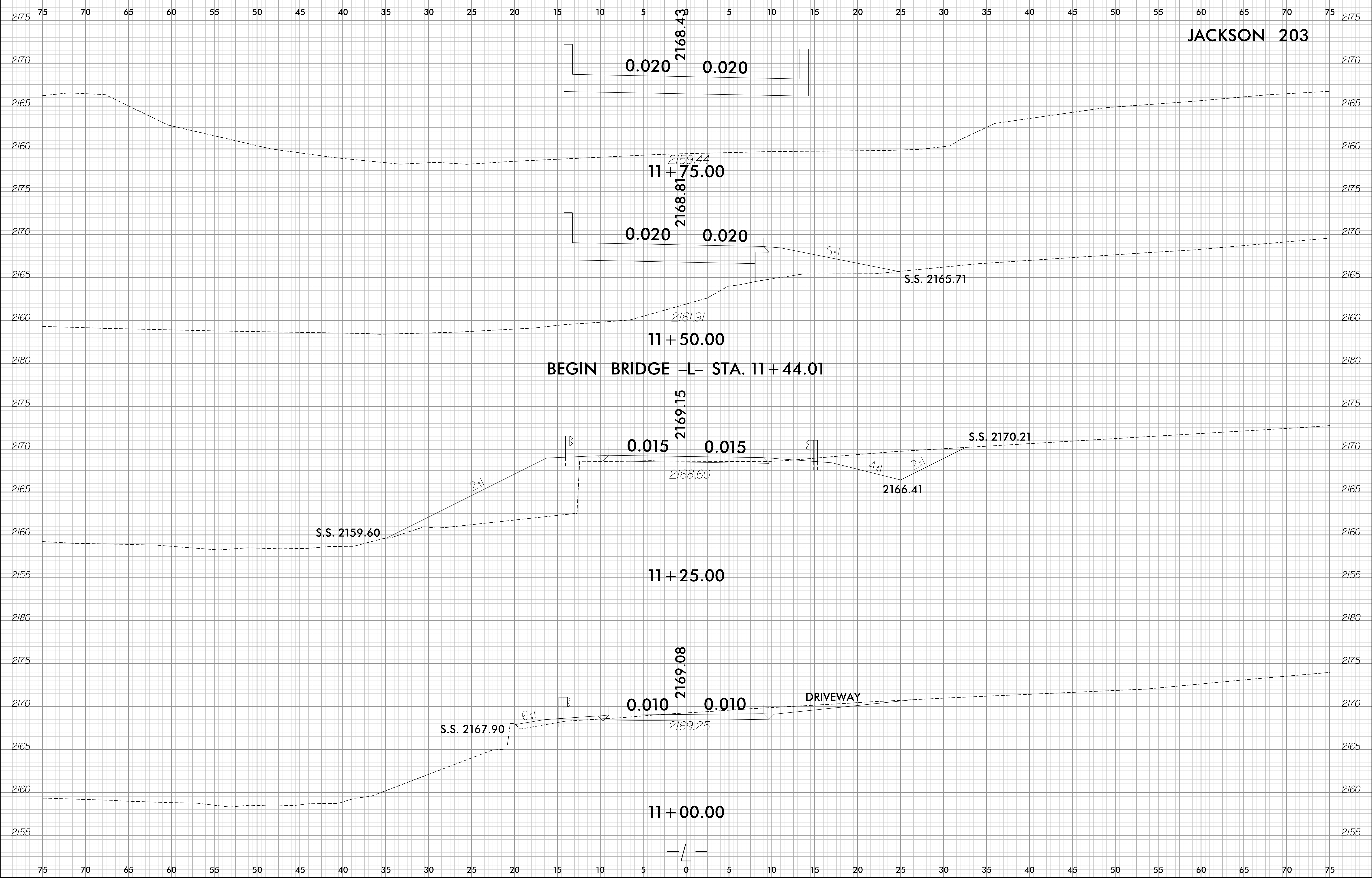

11/4/2012 2:20:48 PM  
\\sc\Jackson203\_rdy\_xpl\_L.dgn  
User:ldaves

8/23/99

0 2.5 5	PROJ. REFERENCE NO.	SHEET NO.
	B-6035	X-3

75 70 65 60 55 50 45 40 35 30 25 20 15 10 5 0 5 10 15 20 25 30 35 40 45 50 55 60 65 70 75

# JACKSON 203

## END PROJECT B-6035 -L- STA. 12 + 90.00

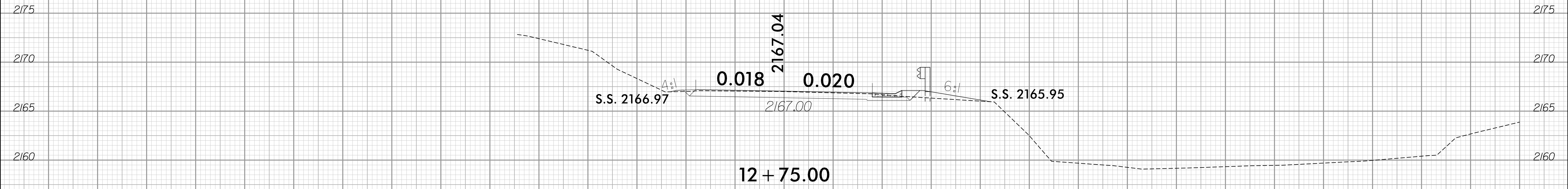

### 12 + 75.00

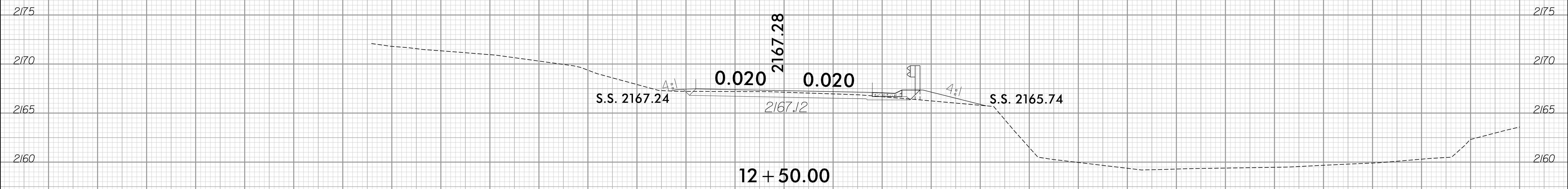

### 12 + 50.00

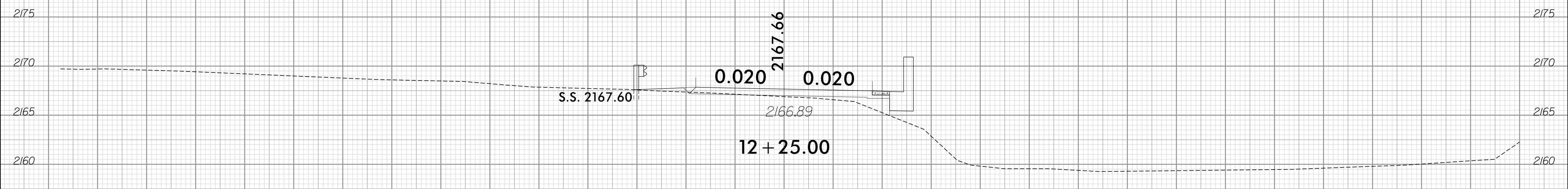

### 12 + 25.00

## END BRIDGE -L- STA. 12 + 16.61

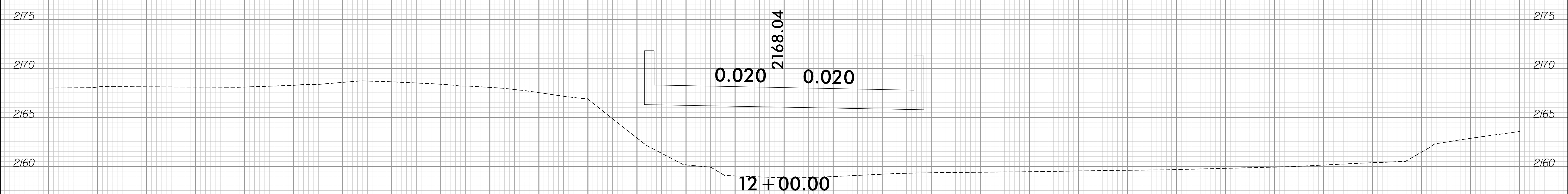

### 12 + 00.00

75 70 65 60 55 50 45 40 35 30 25 20 15 10 5 0 5 10 15 20 25 30 35 40 45 50 55 60 65 70 75

11/5/2017 3:17:28 AM  
X:\sc\Jackson203\_rdy\_xpl.L.dgn  
User:ldaves

8/23/99

0 2.5 5	PROJ. REFERENCE NO.	SHEET NO.
	B-6035	X-4

75 70 65 60 55 50 45 40 35 30 25 20 15 10 5 0 5 10 15 20 25 30 35 40 45 50 55 60 65 70 75

# JACKSON 203

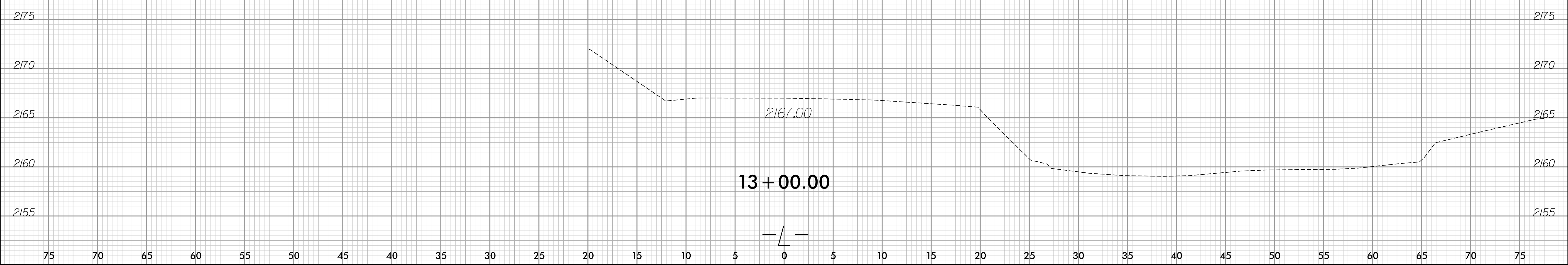

11/5/2017 3:17:28 AM  
\\Xsc\Jackson203\_rdy\_xpl.L.dgn  
User:ldavies

13 + 00.00

